

FOR LEASE: CORNERS WEST BUSINESS PARK



Peachtree Corners, Georgia 30092

FOR MORE
INFORMATION
PLEASE CONTACT

DOUG MYERS
770.729.2822
dmyers@lavista.com

TOM HUNTER
770.729.2829
thunter@lavista.com



3490 Piedmont Road, NE | Suite 1300 | Atlanta, Georgia 30305 | lavista.com

FOR LEASE

Corners West Business Park

Peachtree Corners, Georgia 30092

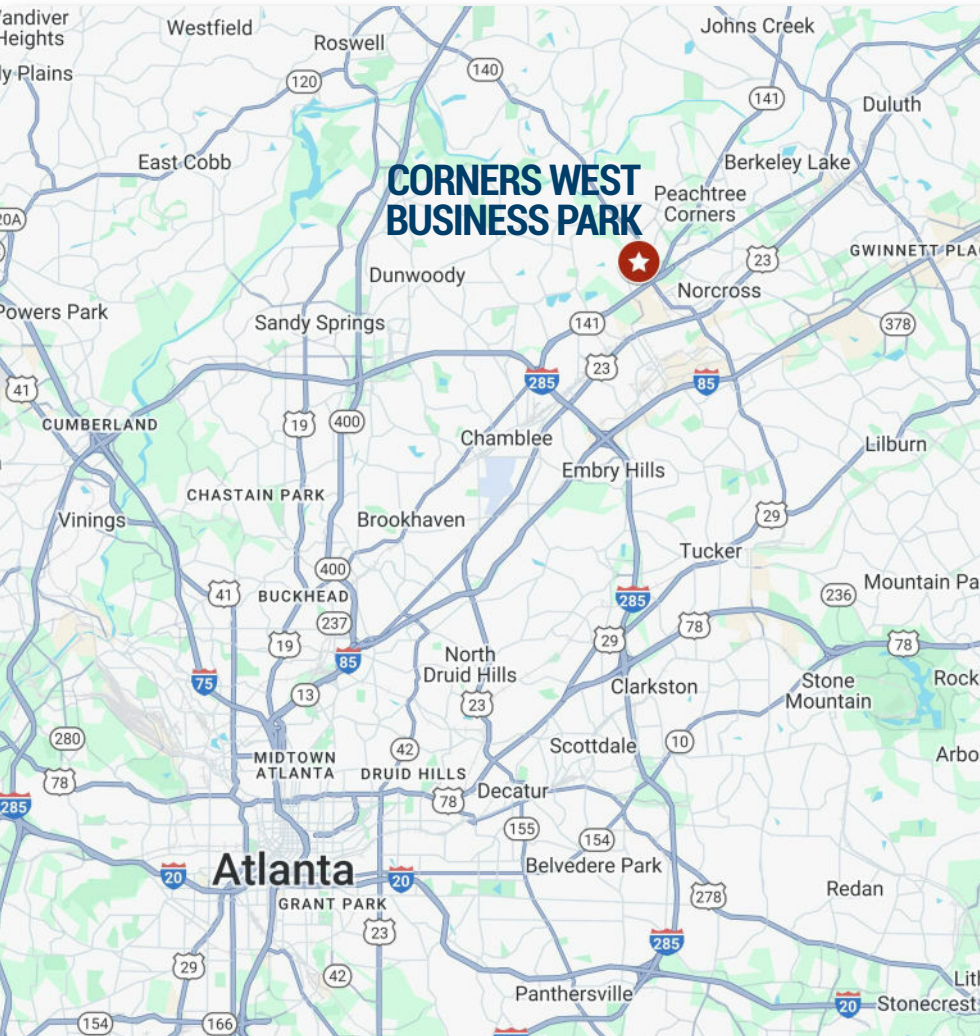

CAMPUS OVERVIEW

Corners West Business Park is an seven (7) building park consisting of 349,695 square feet of flex and industrial space in the Peachtree Corners Submarket. Notable tenants include Fed Ex, Brinks, Southern Tire Mart, Ecycle Atlanta, Property Medics, Coverall of Atlanta, and Bay Insulation.

LOCATION

Corners West Business Park is conveniently located between Jimmy Carter Boulevard and Winters Chappel Road. This location is less than three (3) miles North of the I-285 and Peachtree Industrial Boulevard intersection and provides excellent access to local markets via Peachtree Industrial Blvd., Hwy 141, I-285, and I-85.

PROPERTY FEATURES

- ◆ Attractive buildings with brick and block construction
- ◆ Attractive, mature landscaping
- ◆ Generous parking ratios
- ◆ Close-in Gwinnett location with proximity to a rich amenity base
- ◆ Easy access to major thoroughfares
- ◆ Access to public transportation

FOR MORE
INFORMATION
PLEASE CONTACT

DOUG MYERS
770.729.2822
dmyers@lavista.com

TOM HUNTER
770.729.2829
thunter@lavista.com



FOR LEASE

Corners West Business Park Peachtree Corners, Georgia 30092

BUILDING SPECS

1 3230 PEACHTREE CORNERS CIRCLE

Building Size: 45,808 SF
Total Available: 17,648 SF
Construction Type: Brick and Block
Year Built: 1986
Ceiling Height: 14'
Number of Docks: 0
Number of Drive In's: 14

2 3250 PEACHTREE CORNERS CIRCLE

Building Size: 45,488 SF
Total Available: 14,738 SF
Construction Type: Brick and Block
Year Built: 1983
Ceiling Height: 16'
Number of Docks: 9 (2 ramped)
Number of Drive In's: 8

3 6665 CORNERS INDUSTRIAL COURT

Building Size: 20,000 SF
Total Available: 5,000 SF
Construction Type: Brick and Block
Year Built: 1980
Ceiling Height: 19'
Number of Docks: 8
Number of Drive In's: 0

4 6670 CORNERS INDUSTRIAL COURT

Building Size: 43,772 SF
Total Available: 8,900 SF
Construction Type: Brick and Block
Year Built: 1983
Ceiling Height: 20'
Number of Docks: 6
Number of Drive In's: 2

5 6675 CORNERS INDUSTRIAL COURT

Building Size: 50,040 SF
Total Available: 15,012 SF
Construction Type: Brick and Block
Year Built: 1980
Ceiling Height: 22'
Number of Docks: 9
Number of Drive In's: 1



FOR MORE
INFORMATION
PLEASE CONTACT

DOUG MYERS
770.729.2822
dmyers@lavista.com

TOM HUNTER
770.729.2829
thunter@lavista.com



FOR LEASE

Corners West Business Park

3230 Peachtree Corners Circle

Peachtree Corners, Georgia 30092

3230 PEACHTREE CORNERS CIR | SUITE C | 2,800 SF

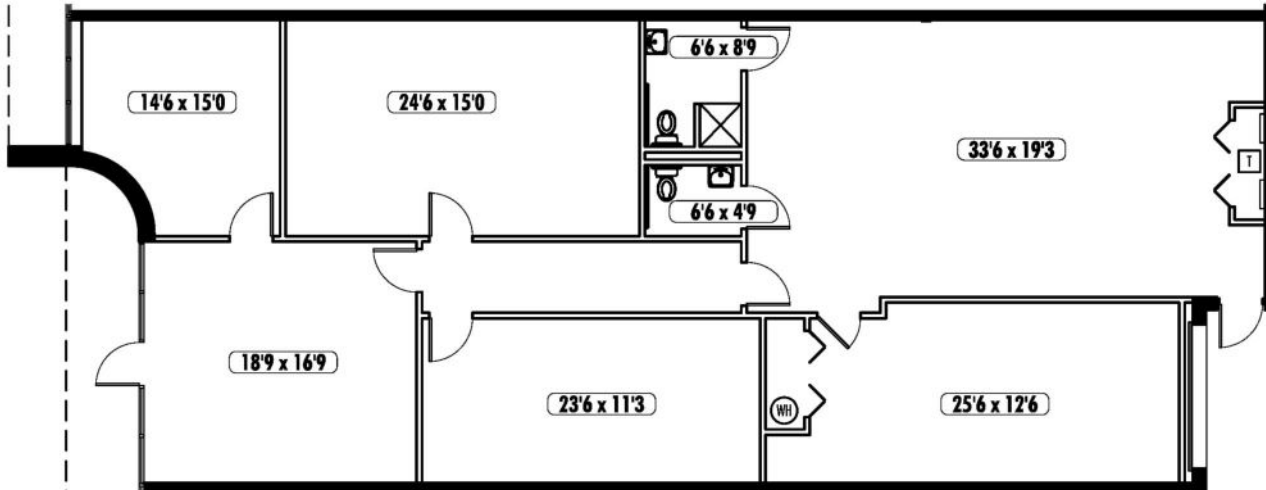

KEY PLAN

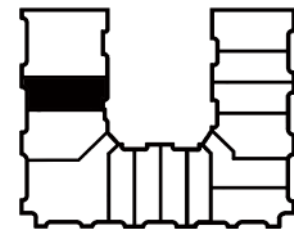

2,800 SF Total
1,742 SF Office
1,058 SF Warehouse
(1) Drive-In Door
14' Clear Height
Wet Sprinkler System

FOR MORE
INFORMATION
PLEASE CONTACT

DOUG MYERS
770.729.2822
dmyers@lavista.com

TOM HUNTER
770.729.2829
thunter@lavista.com



FOR LEASE

Corners West Business Park

3230 Peachtree Corners Circle

Peachtree Corners, Georgia 30092

3230 PEACHTREE CORNERS CIR | SUITE D | 3,679 SF

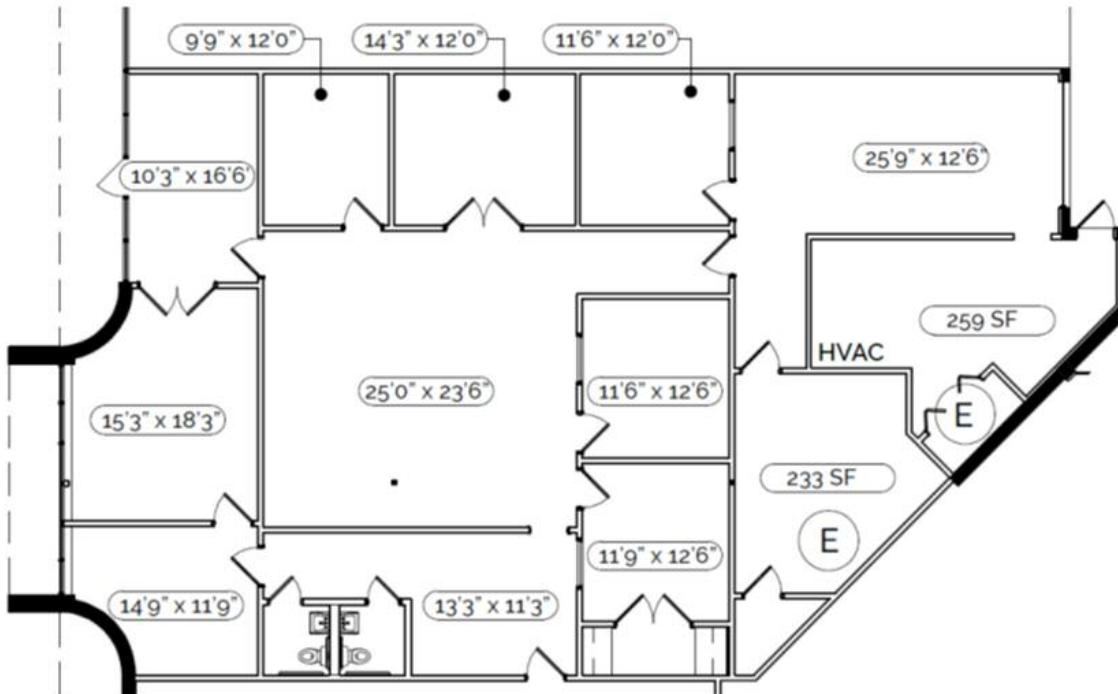

KEY PLAN

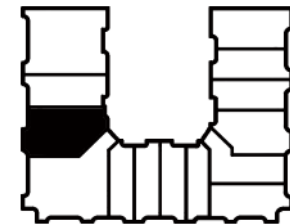

3,679 SF Total

3,679 SF Office

(1) Drive-In Door (Glassed-In)

14' Clear Height

Wet Sprinkler System

FOR MORE
INFORMATION
PLEASE CONTACT

DOUG MYERS
770.729.2822
dmyers@lavista.com

TOM HUNTER
770.729.2829
thunter@lavista.com



FOR LEASE

Corners West Business Park

3230 Peachtree Corners Circle
Peachtree Corners, Georgia 30092

3230 PEACHTREE CORNERS CIR | SUITE H | 5,995 SF

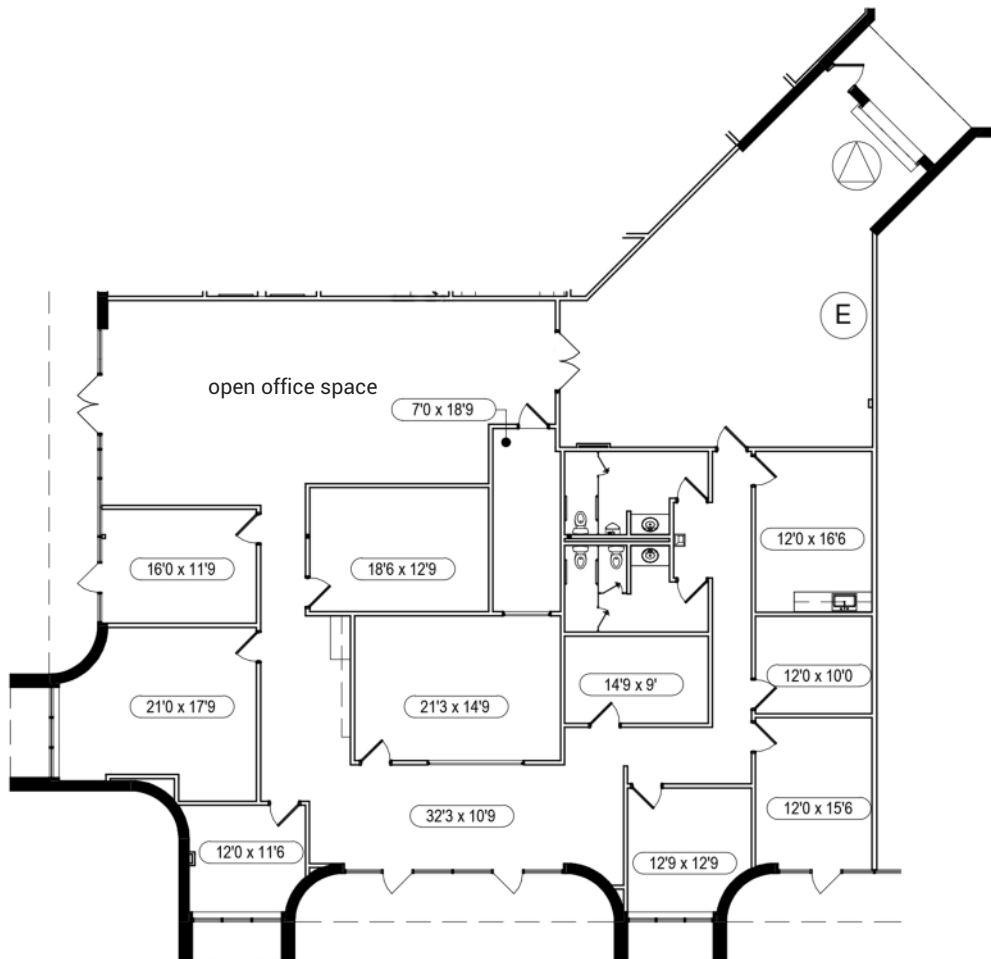

KEY PLAN

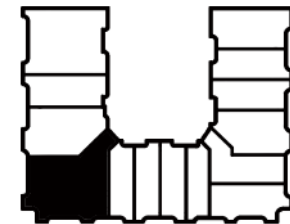

5,995 SF Total
5,048 SF Office
947 SF Warehouse
(1) Drive-In Door
14' Clear Height
Wet Sprinkler System

FOR MORE
INFORMATION
PLEASE CONTACT

DOUG MYERS
770.729.2822
dmyers@lavista.com

TOM HUNTER
770.729.2829
thunter@lavista.com



FOR LEASE

Corners West Business Park

3230 Peachtree Corners Circle
Peachtree Corners, Georgia 30092

3230 PEACHTREE CORNERS CIR | SUITE L | 2,012 SF

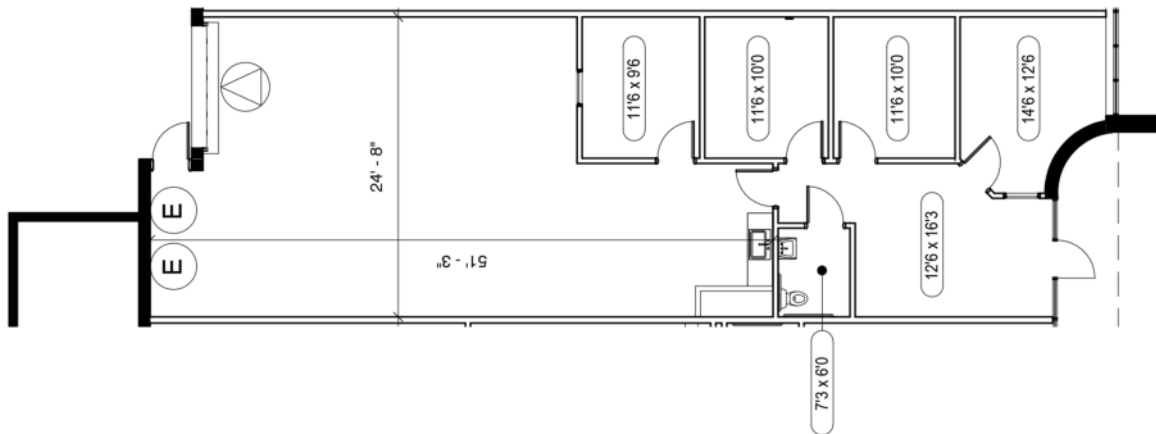

KEY PLAN

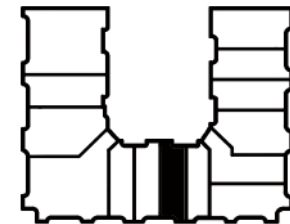

2,012 SF Total
900 SF Office
1,112 SF Warehouse
(1) Drive-In Door
14' Clear Height
Wet Sprinkler System

FOR MORE
INFORMATION
PLEASE CONTACT

DOUG MYERS
770.729.2822
dmyers@lavista.com

TOM HUNTER
770.729.2829
thunter@lavista.com



FOR LEASE

Corners West Business Park

3230 Peachtree Corners Circle

Peachtree Corners, Georgia 30092

3230 PEACHTREE CORNERS CIR | SUITE S | 3,162 SF

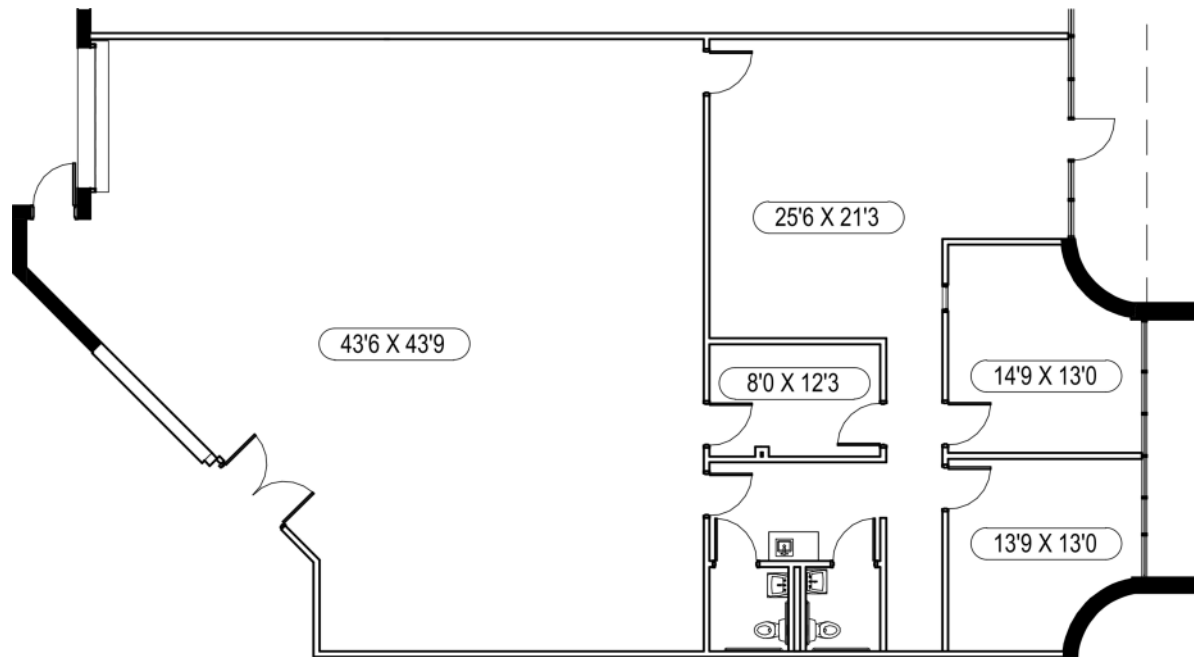

KEY PLAN

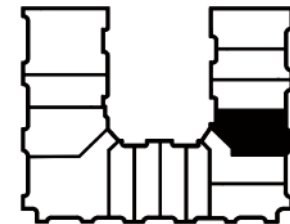

3,162 SF Total

1,248 SF Office

1,914 SF Warehouse

(1) Drive-In Door

14' Clear Height

Wet Sprinkler System

FOR MORE
INFORMATION
PLEASE CONTACT

DOUG MYERS
770.729.2822
dmyers@lavista.com

TOM HUNTER
770.729.2829
thunter@lavista.com



FOR LEASE

Corners West Business Park

3250 Peachtree Corners Circle

Peachtree Corners, Georgia 30092

3250 PEACHTREE CORNERS CIR | SUITE E | 3,680 SF

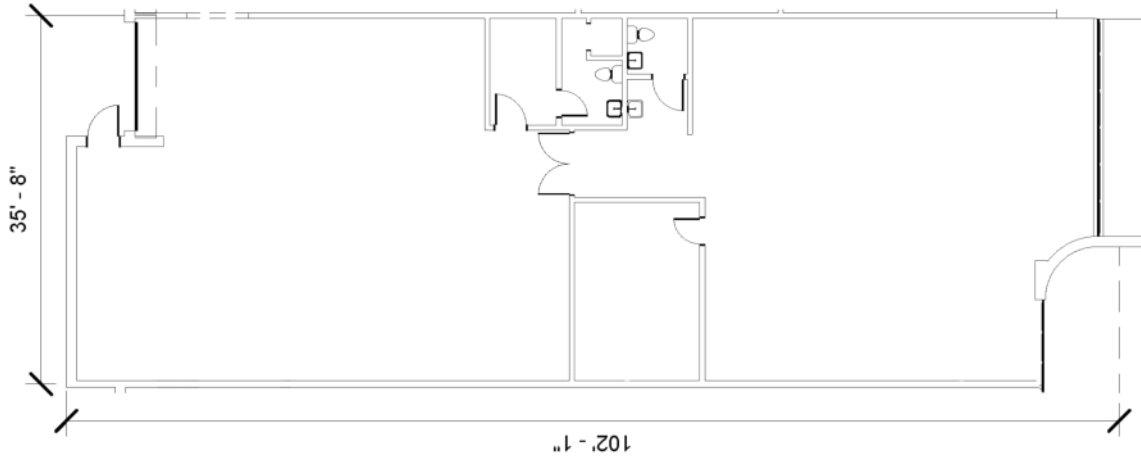

KEY PLAN



3,680 SF Total

(1) Drive-In Door

16' Clear Height

Wet Sprinkler System

FOR MORE
INFORMATION
PLEASE CONTACT

DOUG MYERS
770.729.2822
dmyers@lavista.com

TOM HUNTER
770.729.2829
thunter@lavista.com



FOR LEASE

Corners West Business Park

3250 Peachtree Corners Circle

Peachtree Corners, Georgia 30092

3250 PEACHTREE CORNERS CIR | SUITE F | 3,680 SF

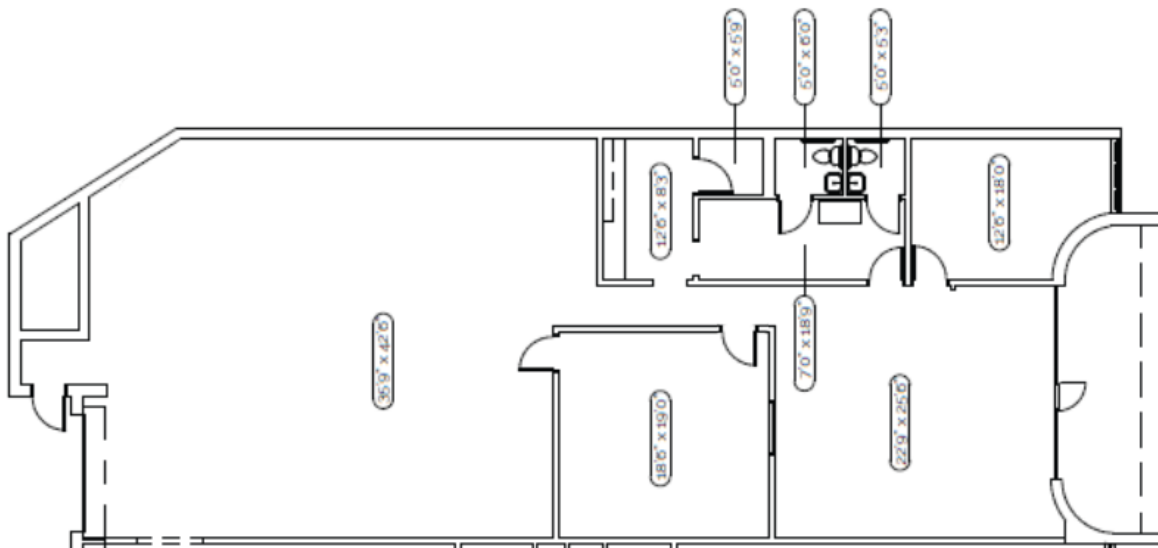

KEY PLAN

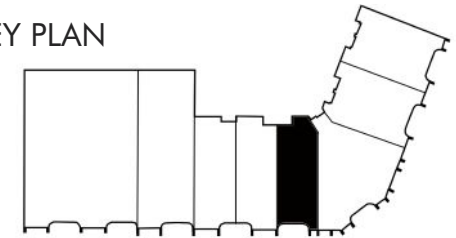

3,680 SF Total

1,697 SF Office

1,983 SF Warehouse

(1) Drive-In Door

16' Clear Height

Wet Sprinkler System

FOR MORE
INFORMATION
PLEASE CONTACT

DOUG MYERS
770.729.2822
dmyers@lavista.com

TOM HUNTER
770.729.2829
thunter@lavista.com



FOR LEASE

Corners West Business Park

3250 Peachtree Corners Circle

Peachtree Corners, Georgia 30092

3250 PEACHTREE CORNERS CIR | SUITE G | 5,290 SF

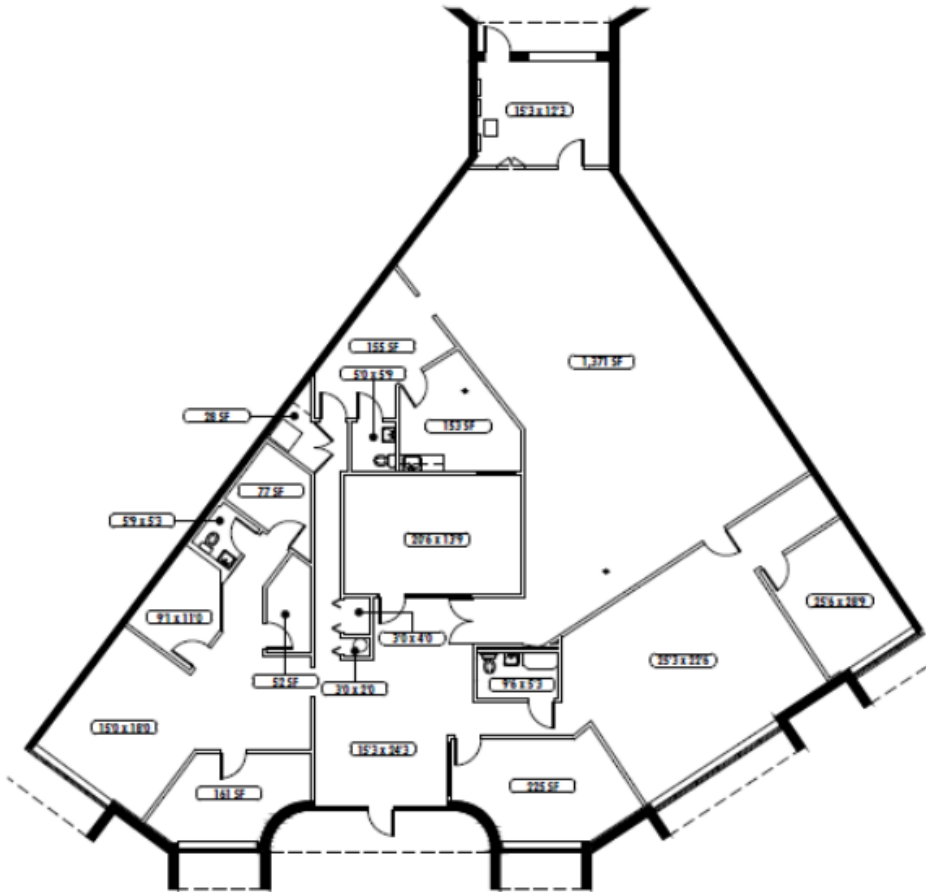

KEY PLAN

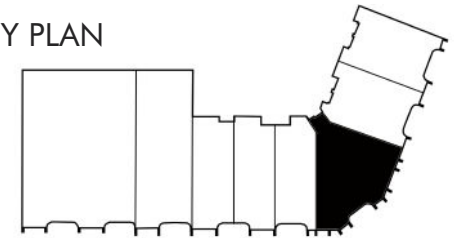

- 5,290 SF Total
- 3,000 SF Office
- 2,290 SF Warehouse
- (1) Drive-In Door
- 16' Clear Height
- Wet Sprinkler System

FOR MORE
INFORMATION
PLEASE CONTACT

DOUG MYERS
770.729.2822
dmyers@lavista.com

TOM HUNTER
770.729.2829
thunter@lavista.com



FOR LEASE

Corners West Business Park

3250 Peachtree Corners Circle

Peachtree Corners, Georgia 30092

3250 PEACHTREE CORNERS CIR | SUITE I | 2,088 SF

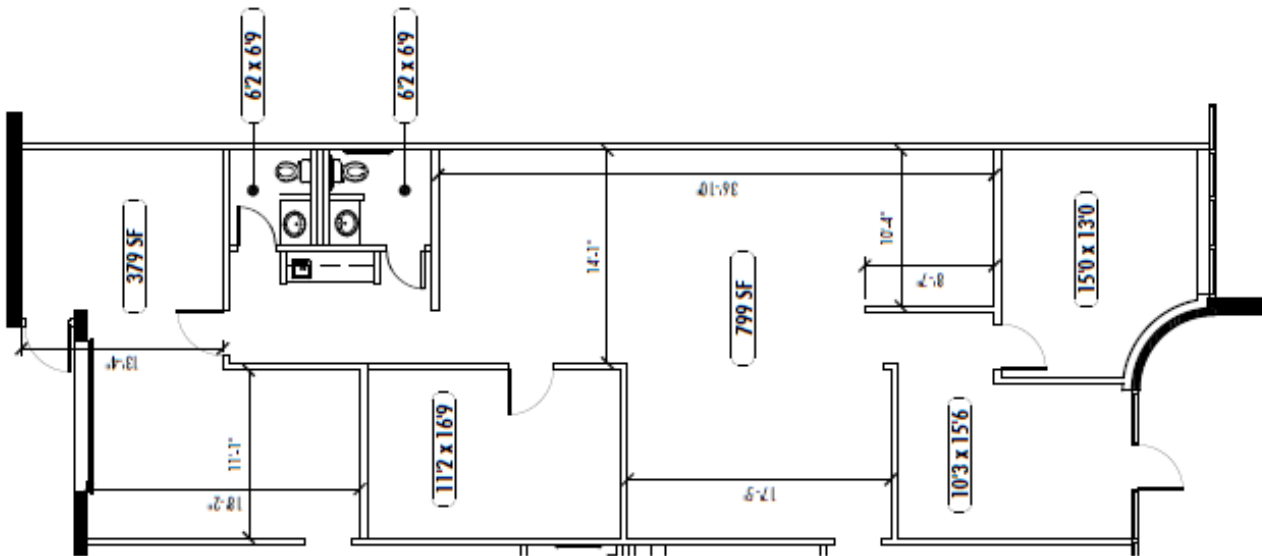

KEY PLAN

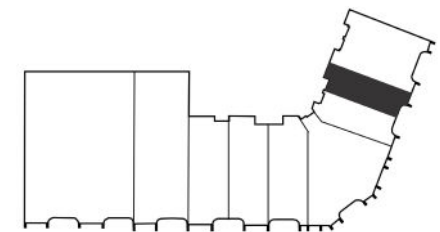

- 2,088 SF Total
- 1,709 SF Office
- 379 SF Warehouse
- (1) Drive-In Door
- 16' Clear Height
- Wet Sprinkler System

FOR MORE
INFORMATION
PLEASE CONTACT

DOUG MYERS
770.729.2822
dmyers@lavista.com

TOM HUNTER
770.729.2829
thunter@lavista.com



FOR LEASE

Corners West Business Park

6665 Corners Industrial Court

Peachtree Corners, Georgia 30092

6665 CORNERS INDUSTRIAL CT | SUITE A | 5,000 SF

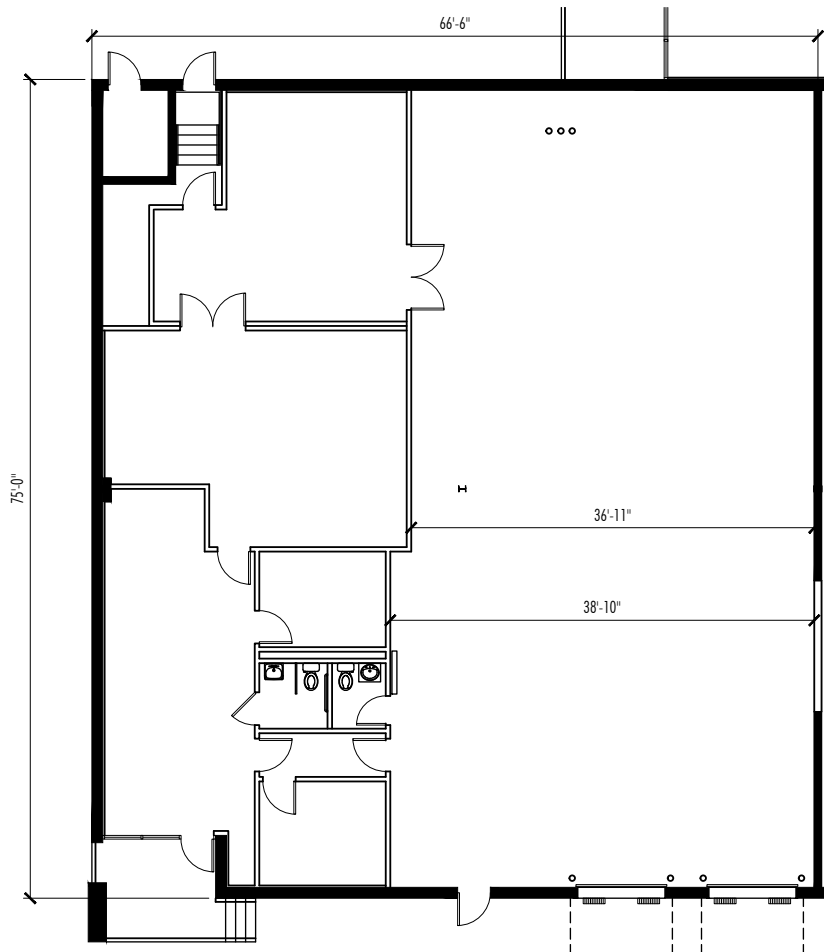

KEY PLAN

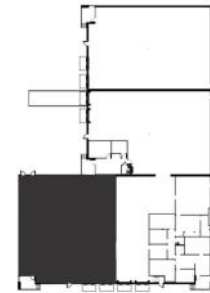

5,000 SF Total

2,060 SF Office

2,940 SF Warehouse

(2) Dock-High Doors

19' Clear Height

Wet Sprinkler System

FOR MORE
INFORMATION
PLEASE CONTACT

DOUG MYERS
770.729.2822
dmyers@lavista.com

TOM HUNTER
770.729.2829
thunter@lavista.com



FOR LEASE

Corners West Business Park

6670 Corners Industrial Court
Peachtree Corners, Georgia 30092

6670 CORNERS INDUSTRIAL CT | SUITE B | 8,900 SF

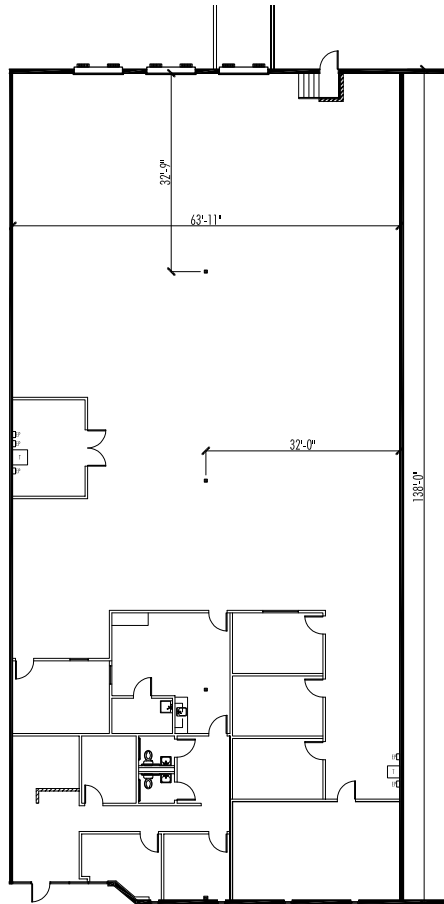

KEY PLAN

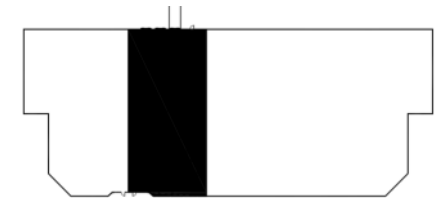

8,900 SF Total

1,585 SF Office

7,315 SF Warehouse

(3) Dock-High Doors (1 ramped)

20' Clear Height

Wet Sprinkler System

FOR MORE
INFORMATION
PLEASE CONTACT

DOUG MYERS
770.729.2822
dmyers@lavista.com

TOM HUNTER
770.729.2829
thunter@lavista.com



FOR LEASE

Corners West Business Park

6675 Corners Industrial Court
Peachtree Corners, Georgia 30092

6675 CORNERS INDUSTRIAL CT | SUITE A | 15,012 SF

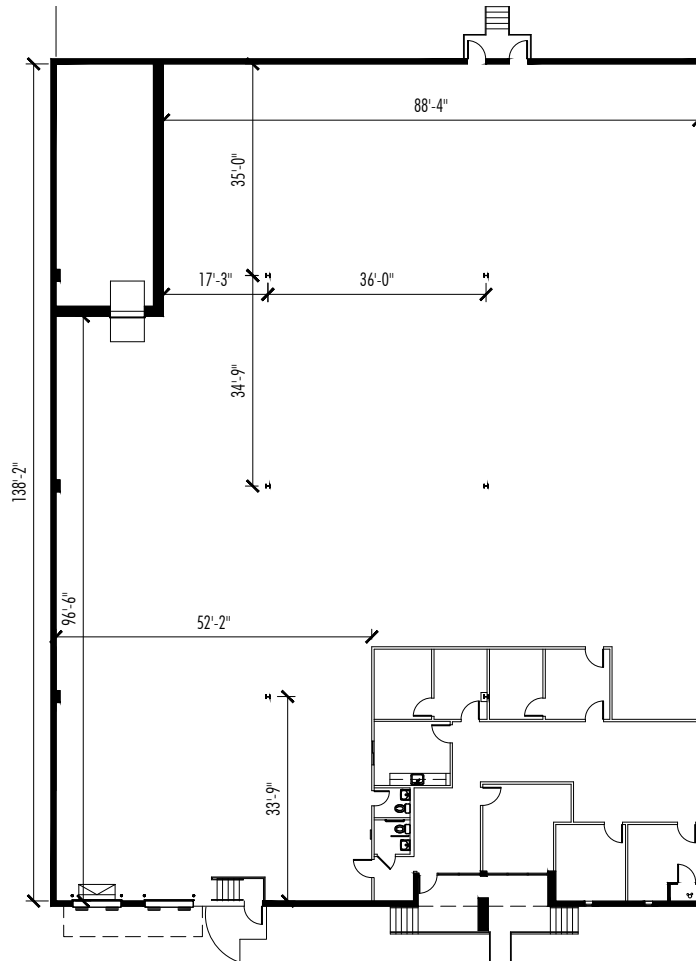

KEY PLAN

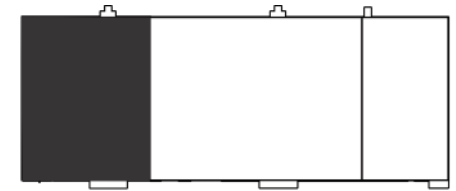

- 15,012 SF Total
- 1,511 SF Office
- 13,501 SF Warehouse
- (2) Dock-High Doors
- 22' Clear Height
- Wet Sprinkler System

FOR MORE
INFORMATION
PLEASE CONTACT

DOUG MYERS
770.729.2822
dmyers@lavista.com

TOM HUNTER
770.729.2829
thunter@lavista.com





FOR MORE
INFORMATION
PLEASE CONTACT

DOUG MYERS
770.729.2822
dmyers@lavista.com

TOM HUNTER
770.729.2829
thunter@lavista.com



DISCLOSURE AND DISCLAIMER: Lavista Associates, Inc. ("Broker") is acting as agent for, and being compensated by, the Owner of this Property, and is not acting as agent for the prospective purchaser or tenant. Broker provides the within information together with all other information of every type, herewith or later provided, only to expedite a potential purchaser's or tenant's decision of whether to proceed with an independent in-depth investigation of the property. Said information shall not be used for any other purpose. All information provided by Broker is not guaranteed or warranted and may not cover all material facts. Broker expressly disclaims all express or implied responsibility for errors, omissions, representations with respect to matters of price, value, income, expense, legal or tax consequences, conditions of soil, structure, roof or operating systems, investment potential, compliance with applicable law, suitability for intended use or any other matter. Potential purchasers or tenants are responsible for verifying all material considerations and insuring that their offer is contingent upon such verification. The availability of the property is subject, without notice, to changes, prior sale, or withdrawal at any time. Financing, loan assumptions and leases are subject to credit approval and other conditions. This document is not an offer open for acceptance. Broker has no power to obligate or bind the Owner of the Property. Owner may be bound only by a formal written agreement fully executed by all parties at interest, which agreement may be subject to conditions or rejection without reason. In consideration for the within information the recipient 1) accepts and uses the information and related material subject to these conditions, 2) agrees to rely solely on its right, and assumes the duty, to independently obtain and analyze all material information, and 3) agrees not to rely on any information provided by Broker. Persons associated with Broker may not alter or modify these provisions. Sub-agents of Broker and agents representing any purchaser or tenant shall disclose these terms to their prospects. Reproduction hereof, in whole or in part, without the prior written permission of Broker is strictly prohibited. (Rev. 5-88)